

**BILL OF MATERIAL**

| PKM    | QTY           | DESCRIPTION        | LENGTH    | FINISH | REMARKS   | GRADE | UNIT | TOTAL WEIGHT |
|--------|---------------|--------------------|-----------|--------|-----------|-------|------|--------------|
| 1S2    | ONE           | STAIR              |           |        |           |       |      | 797 797      |
| 1S2L1  | 1             | MC12x14.3          | 3 7/16    |        |           | A36   | 52   | 52           |
| 1S2R1  | 1             | MC12x14.3          | 4 0/16    |        |           | A36   | 58   | 58           |
| 1S2R0  | 1             | MC12x14.3          | 3 0/16    |        |           | A36   | 43   | 43           |
| 1S2L   | 1             | MC12x14.3          | 8 0 11/16 |        |           | A36   | 115  | 115          |
| 1S2R   | 1             | MC12x14.3          | 8 7 1/8   |        |           | A36   | 123  | 123          |
| hss262 | 1             | HSS6x6x1/2         | 3 9 11/16 |        |           | A500B | 132  | 132          |
| a353   | 14            | 1 L1 1/2x1 1/2x1/4 | 0 9       |        |           | A36   | 2    | 25           |
| a354   | 12            | 1 L1 1/2x1 1/2x1/4 | 0 3       |        |           | A36   | 1    | 7            |
| a347   | 2             | 1 L1 1/2x1 1/2x1/4 | 0 2       |        |           | A36   | 0    | 1            |
| a549   | 1             | 1 L2x2x1/4         | 2 8 7/8   |        |           | A36   | 9    | 9            |
| a549   | 1             | 1 L2x2x1/4         | 2 6 7/8   |        |           | A36   | 8    | 8            |
| p241   | 1             | 1 PL3 1/2x3 1/2    | 0 6       |        |           | A36   | 2    | 2            |
| p230   | 1             | 1 PL3 1/2x2 1/2    | 0 2 1/2   |        |           | A36   | 1    | 1            |
| p253   | 1             | 1 PL 1/4x4 1/2     | 0 7 1/2   |        |           | A36   | 2    | 2            |
| p229   | 1             | 1 PL 1/4x4 1/2     | 0 7 3/4   |        |           | A36   | 1    | 1            |
| tp23   | 7             | BTPT2G4x2 1 1/2    | 3 9 1/8   |        | BENT      | A36   | 29   | 206          |
| tp22   | 1             | BTPT2G4x3 1/4      | 3 9 1/8   |        | BENT      | A36   | 12   | 12           |
|        |               | FIELD BOLTS        |           |        |           |       |      |              |
| 6      | 3/4 Dia A329N |                    | 0 2       |        | +1HD WASH |       |      |              |

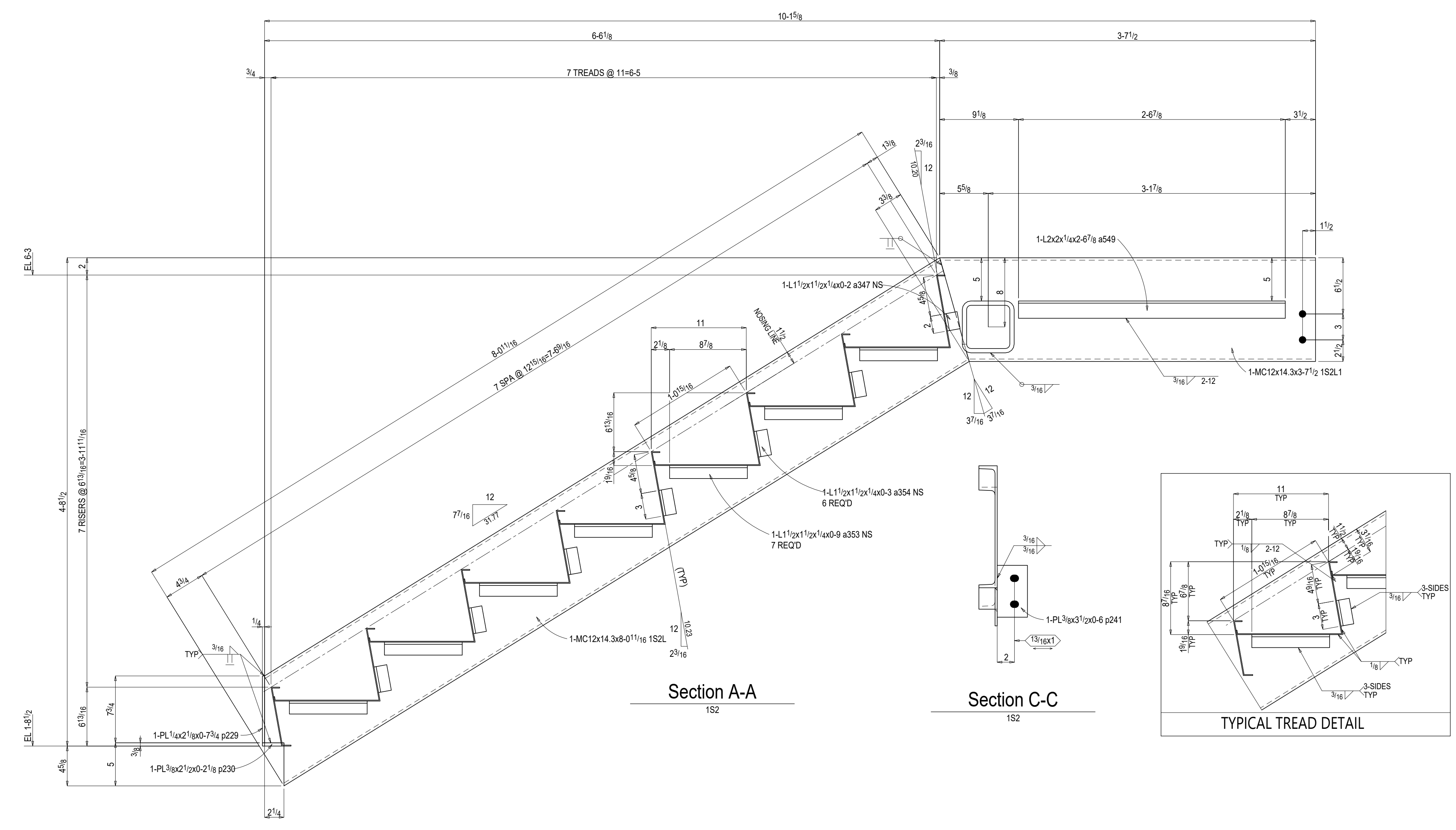
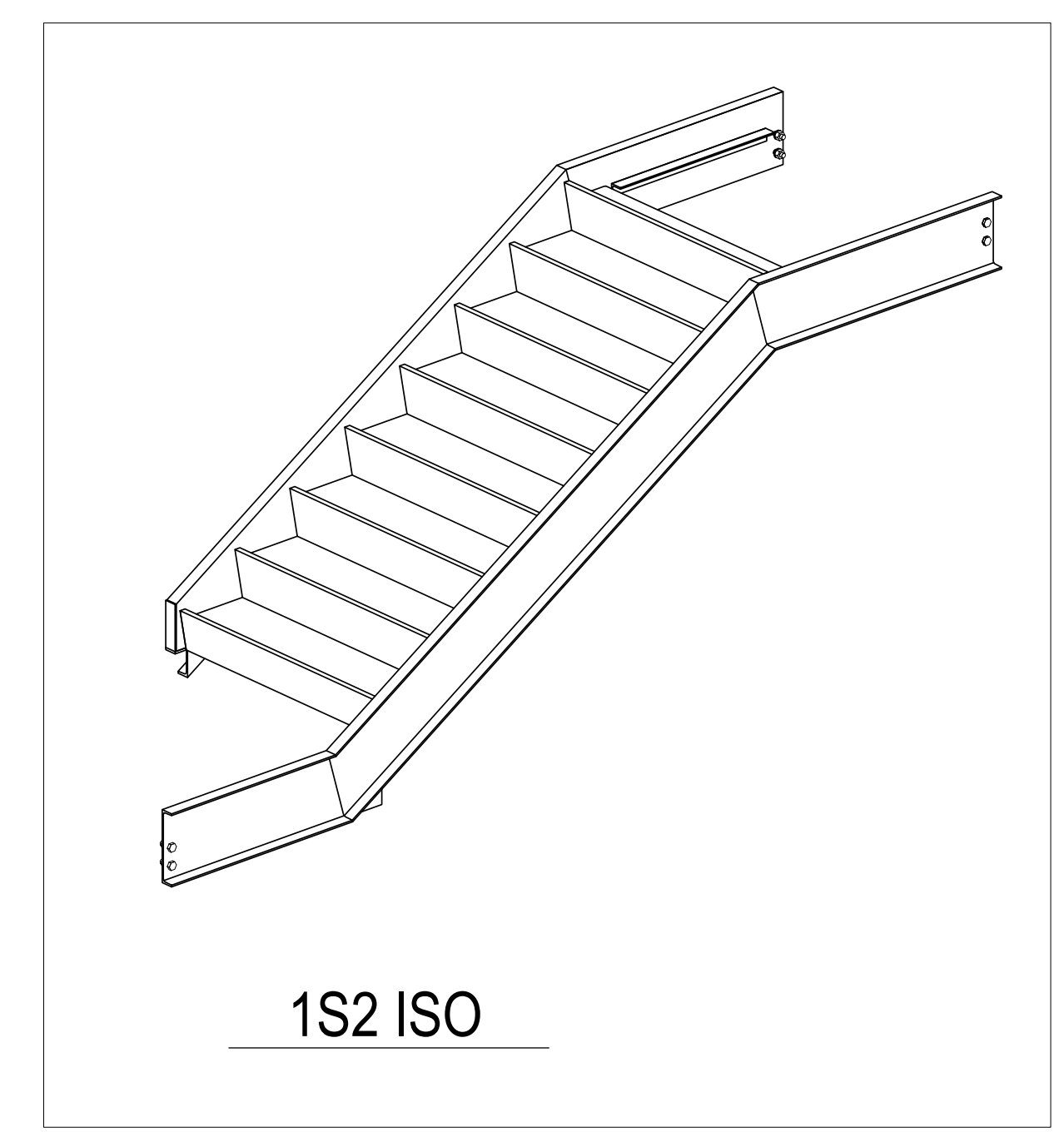
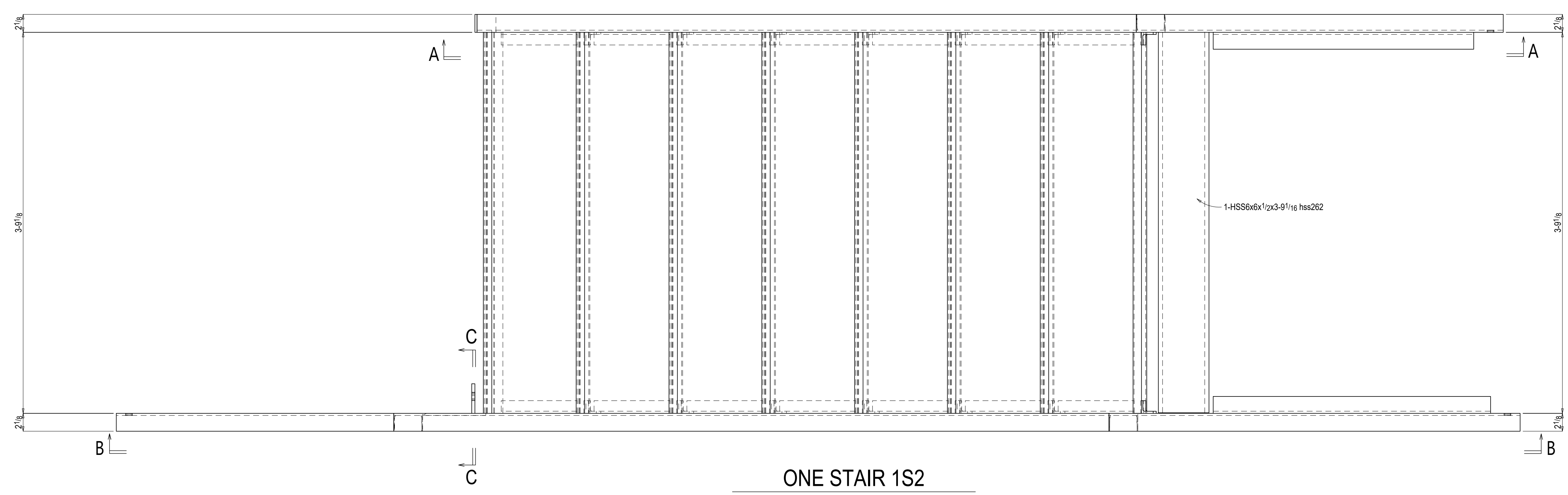

WORK THIS SHEET WITH 1S2A