

# BILL OF MATERIAL

PMK	QTY	DESCRIPTION	LENGTH		FINISH	REMARKS	GRADE	UNIT	TOTAL	
			FT	INCH					WEIGHT	WEIGHT
R2008	ONE	HANDRAIL				Galv			217	217
R2008	1	HSS2x2x3/16	13	0 7/8			A500C	56	56	
hss495	3	HSS2x2x3/16	4	2 3/8			A500C	18	54	
hss509	1	HSS2x2x3/16	3	7/8			A500C	16	16	
hss492	1	HSS2x2x3/16	3	4 1/4			A500C	14	14	
hss491	2	HSS2x2x3/16	3	3 1/8			A500C	14	28	
pp461	1	PIPE 1 1/4 STD	20	3 9/16			A53	46	46	
rb71	4	RB 5/8	0	5 9/16			A36	0	2	

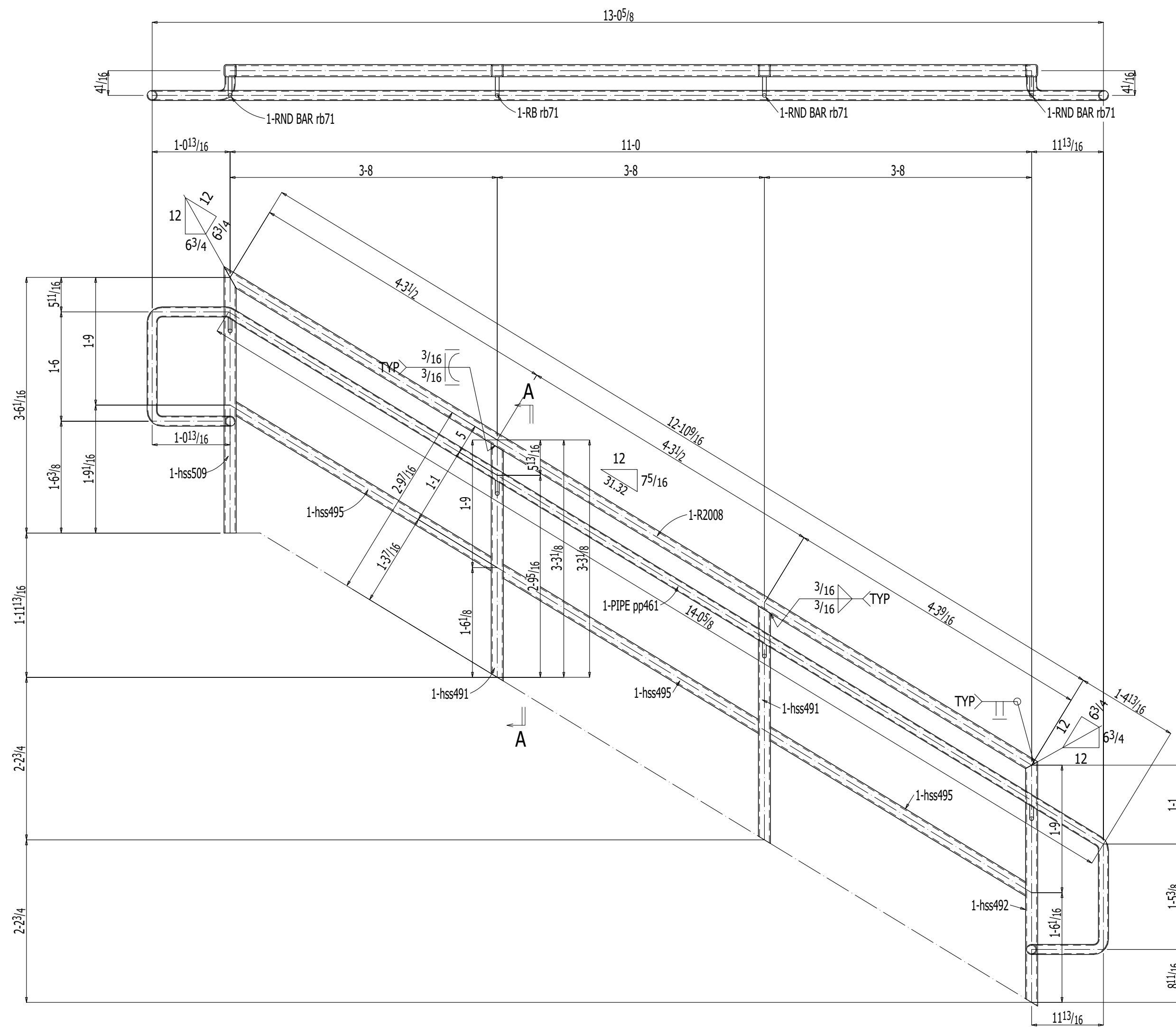

**ONE HANDRAIL R2008**

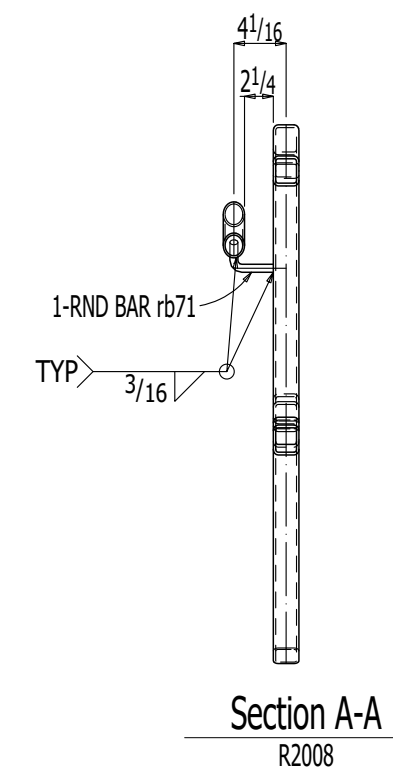

**Section A-A**  
R2008

- SHOP NOTE:**
- 1) ALL WELD TO BE SEALED WELD.
  - 2) PROVIDE VENT HOLE AS REQUIRED.
  - 3) PLUG ALL VENT HOLE AFTER GALVANIZING.