

BILL OF MATERIAL

PMK	QTY	DESCRIPTION	LENGTH		FINISH	REMARKS	GRADE	UNIT	TOTAL
			FT	INCH					
1C2	ONE	COLUMN						4263	4263
1C2	1	W12x106	28	11 1/2		S2E	A992	3070	3070
a208	1	L3x3x1/4	0	5			A36	2	2
p929	1	PL21/2x36	3	0			A572-50	919	919
p819	1	PL1x107/8	2	6 5/8			A572-50	94	94
p39	1	PL3/4x4	3	0			A572-50	31	31
p827	1	PL5/8x5 5/8	1	2 5/8			A36	15	15
p1136	1	PL1/2x12 3/16	1	0 7/8			A36	22	22
p1098	1	PL1/2x9 3/16	1	5 1/2			A36	24	24
p1094	1	PL1/2x9 3/16	1	5 1/2			A36	24	24
p815	1	PL1/2x5 3/16	0	10 7/8			A572-50	9	9
p816	3	PL1/2x5 3/16	0	10 7/8			A572-50	9	27
p885	1	PL1/2x5 7/16	1	2 3/4			A36	11	11
p826	2	PL1/2x4 13/16	0	10 7/8			A572-50	7	15

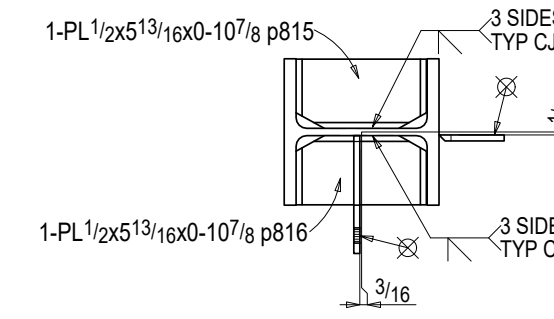

Section C-C
1C2

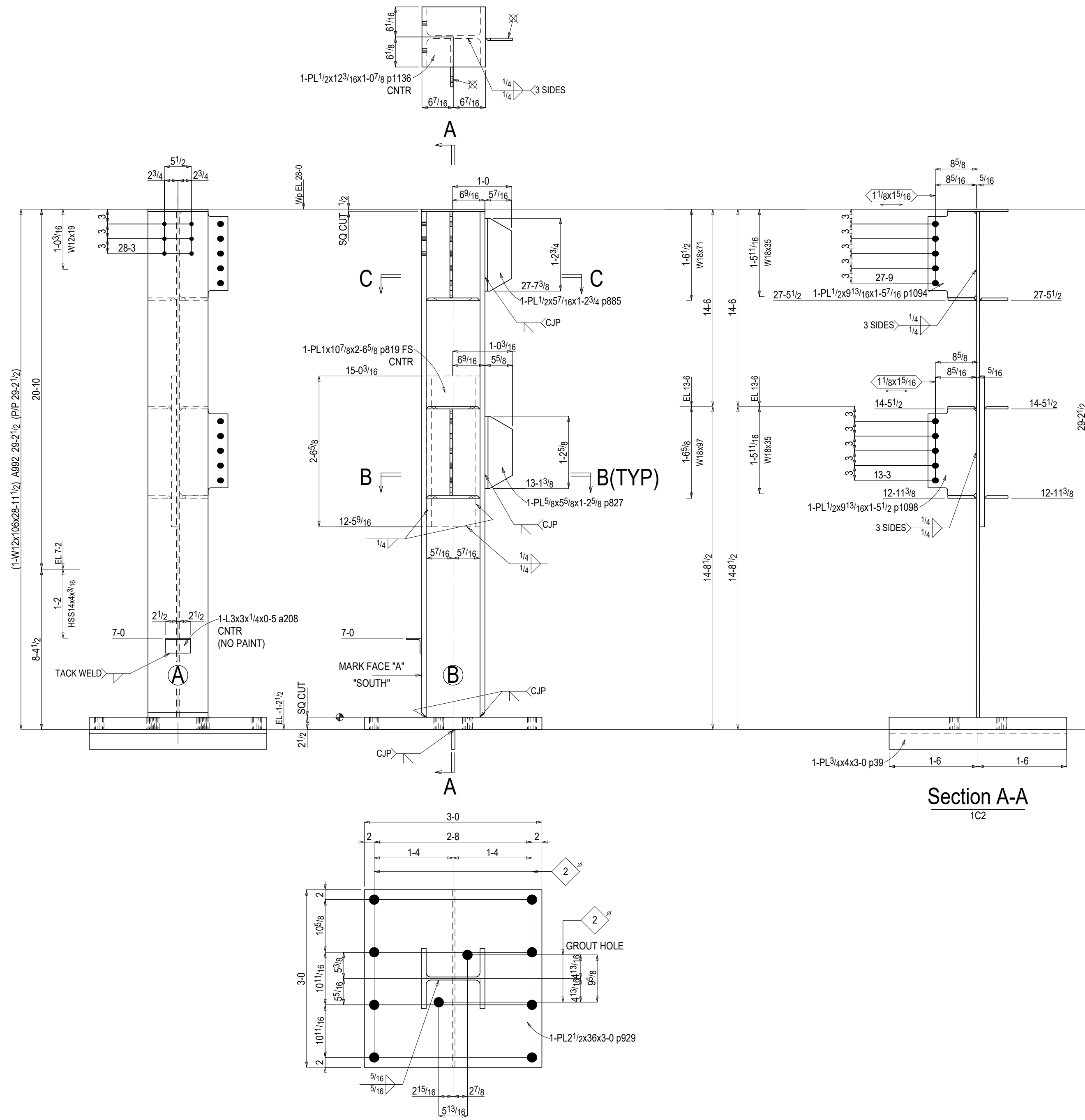
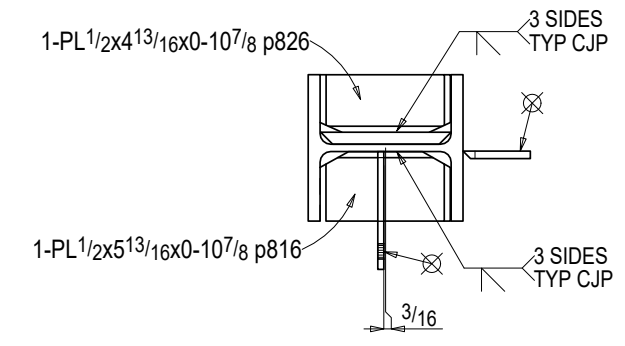

Section B-B
1C2

ONE COLUMN 1C2

W 12 7/8 x 5 5/8
F 12 3/16 x 1
K 17 8 x 13 1/16

AT GRID:
3 & A