

BILL OF MATERIAL

PCMK	QTY	DESCRIPTION	LENGTH	REMARKS	STEEL GRADE	WEIGHT UNIT	WEIGHT TOTAL
M2024	ONE	LADDER				689	689
a657	2	L3x3x3/8	0	3	A572-50	2	4
rb684	29	RB3/4	1	6 3/8	A572-50	2	67
p561	2	PL3/8x3	32	1 1/4	A572-50	121	242
btp54	14	BTP3/8x3	0	11	A572-50	3	48
btp57	1	BTP1/4x3	7	1 1/16	A572-50	20	20
btp55	1	BTP1/4x3	9	8 1/8	A572-50	25	25
btp56	5	BTP1/4x2	7	1 1/16	A572-50	14	68
btp60	7	BTP1/4x1 1/2	24	1 1/16	A572-50	31	216
		FIELD BOLTS					
	14	3/4 Dia SleeveAnc	0	6			
	2	1/2 Dia Hilti KW	0	6			

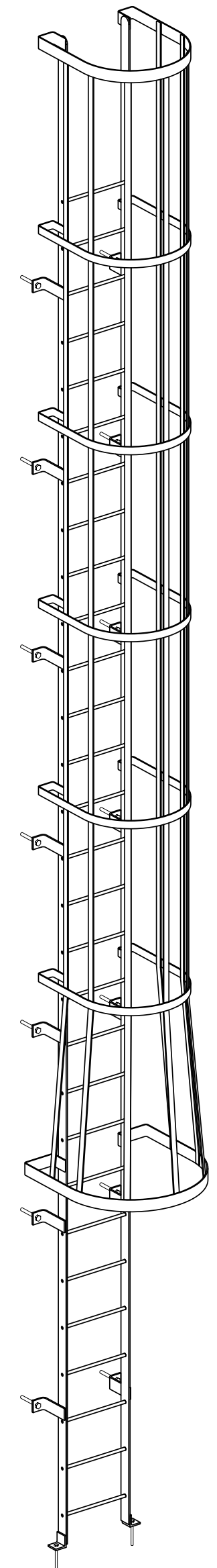
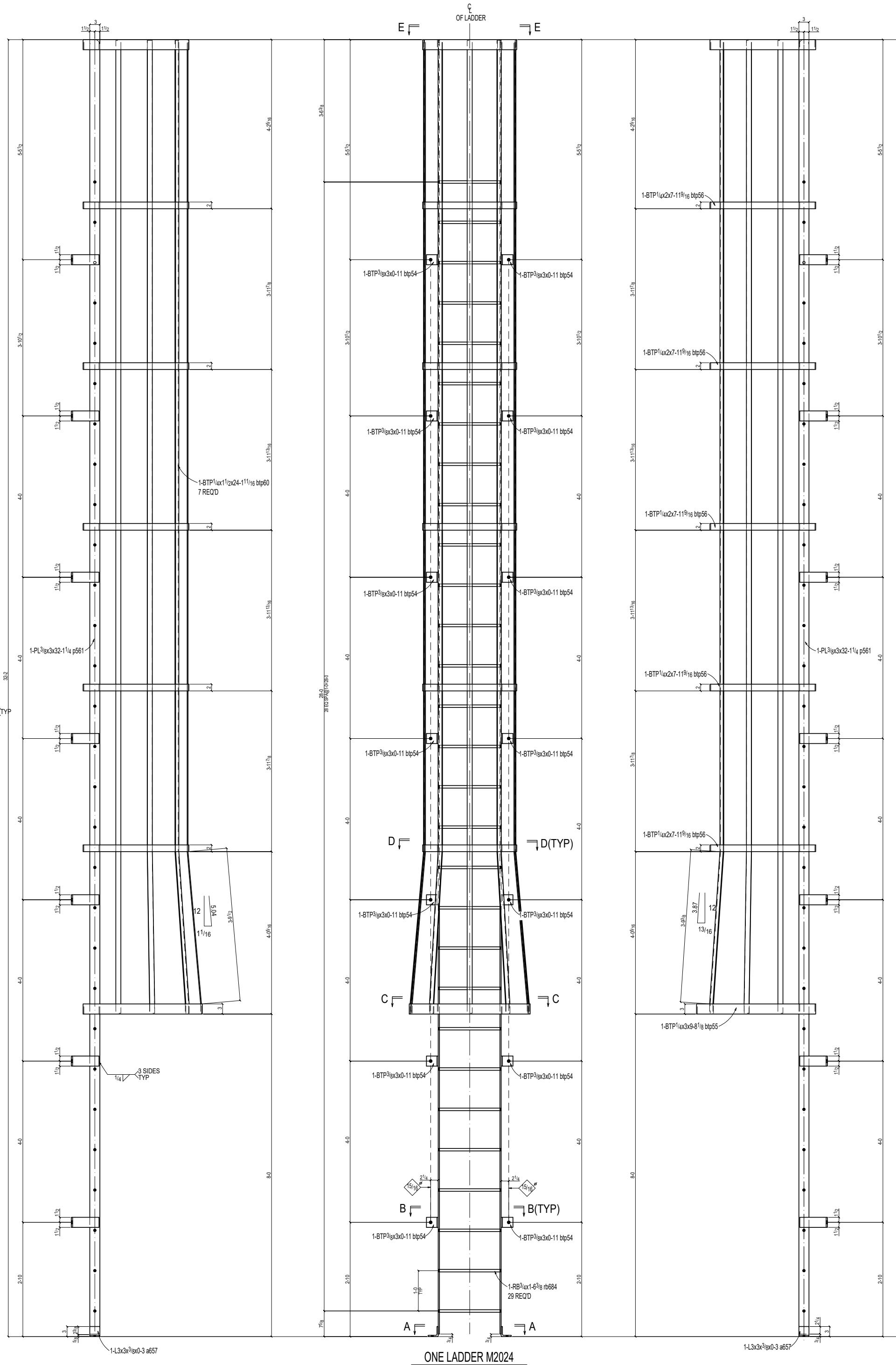
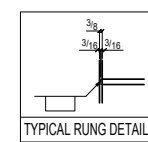
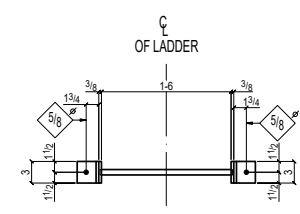
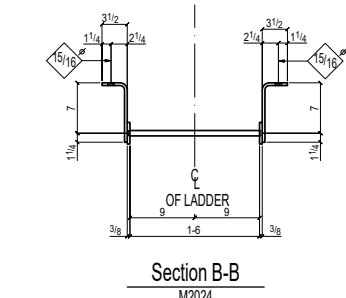
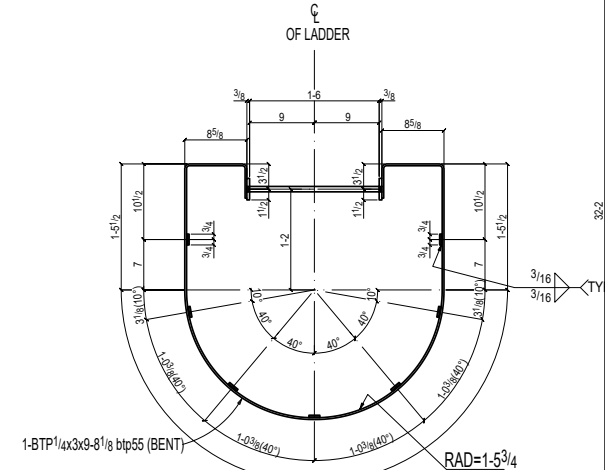
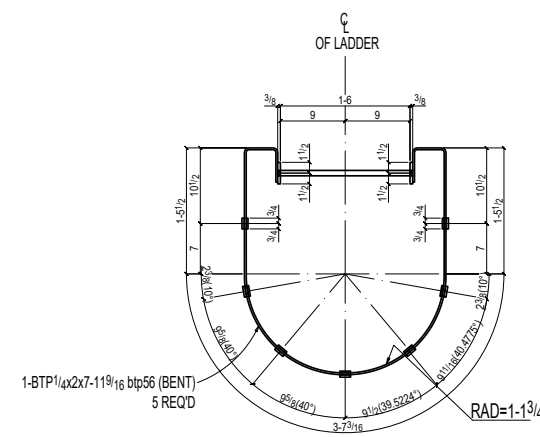
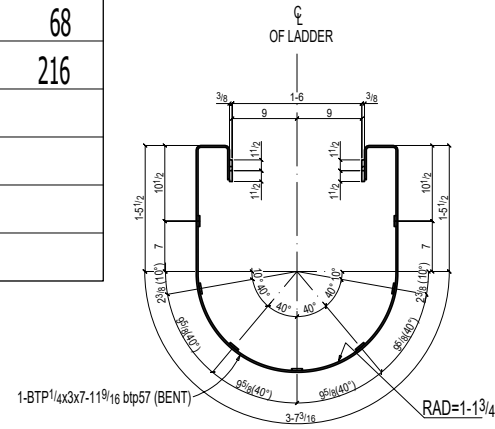

ISO VIEW